



**50** YEARS



## STRAUB-PLAST-PRO

**Safe, quick and simple!**

The complete kit ensures safe pipe connections done quickly and easy with a minimal effort in pipe end preparation. STRAUB-PLAST-PRO is the well-proven alternative to electro-fusion.

# THE PE COMPLETE KIT

## STRAUB-PLAST-PRO

An axially restrained jointing system allowing a quick and simple installation of pressure pipes made of polyethylene (PE).

STRAUB-PLAST-PRO offers an alternative to traditional jointing methods of PE used in water, waste water, industrial plants and maintenance applications. The complete kit is available for PE pipes in dimension SDR 11 (63.0-180.0 mm; PN 16) and SDR 17 (125.0-355.0 mm; PN 10).

The full product range offers the great advantage that pipes can easily be connected without the need of external power supply and pipe end preparation, even under demanding external weather conditions.

The pipes made of PE 80 or PE 100 are connected with a combination of liner inserts and external shells. The jointing concept allows the product to be assembled easily and is difficult to get wrong.

PE pipes with added protective coatings are available in a variety of designs such as PE pipes with a diffusionproof aluminium foil barrier layer that are commonly preferred to be laid in contaminated soil sites. Thus, pollutants are prevented from entering into the pipe and the medium is prevented from getting into ground soil.

STRAUB-PLAST-PRO also connects such barrier layer pipes easily and safely without any pipe end preparation. Before assembly the pipe outside diameter should be confirmed and checked that it fits into the working range of the individual shell.



Example for ordering | DIN EN:  
STRAUB-PLAST-PRO L d90.0, SDR 11

Example for ordering | multilayer:  
STRAUB-PLAST-PRO FA d63/DN 50, SDR 11; OD 64-66mm

The product range of STRAUB-PLAST-PRO is combined from different liner inserts and external shells. By this versatile formed-parts-program PE-pipes can be connected easily and fast in every situation.

**STRAUB-PLAST-PRO L**  
Coupler



**STRAUB-PLAST-PRO LR**  
Repair-Coupler  
(repairs up to 100 mm)



**STRAUB-PLAST-PRO R**  
Reducer



**STRAUB-PLAST-PRO B90**  
Elbow 90°



**STRAUB-PLAST-PRO B45**  
Elbow 45°



**STRAUB-PLAST-PRO T**  
Equal Tee



**STRAUB-PLAST-PRO TFA**  
Flanged Branch Tee <sup>1</sup>



**STRAUB-PLAST-PRO FB90**  
Duck Foot Bend 90° <sup>1</sup>



STRAUB-PLAST-PRO has been successfully tested according to the **British Standard WIS 4-24-01** and fulfil the requirements to:

- German Standard DVGW-VP609
- European Standard EN 1254-3



**STRAUB-PLAST-PRO FA**  
Flange Adapter <sup>1</sup>  
(loose flange ring is included)



<sup>1</sup> flange bolt set is not supplied (DIN EN 1092-1)

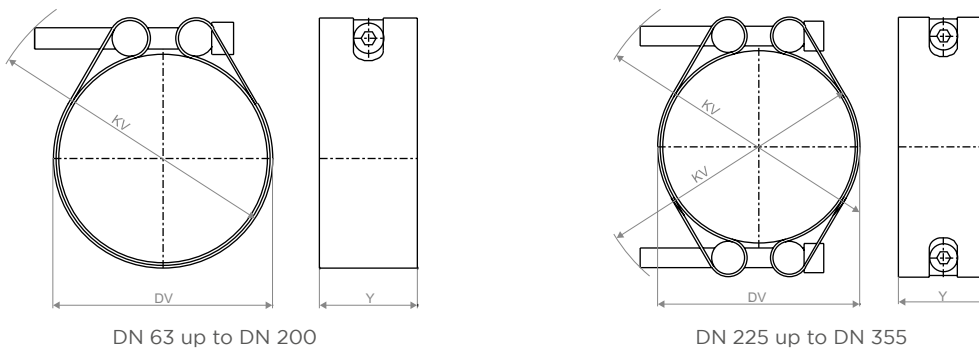

DN	DV braced		KV braced		Y [mm]	Allen head [mm]	Thread M..	Torque rate [Nm]
	DIN <sup>3</sup> [mm]	multilayer [mm]	DIN [mm]	multilayer [mm]				
63	65	67	95	95	47.5	10	12	50
75	79	82 <sup>2</sup>	106	107	47.5	10	12	55
90	94	97	120	121	47.5	10	12	60
110	113	117	139	140	55	10	12	60
125	129	132	155	156	55	10 / 14 <sup>4</sup>	12 / 16 <sup>4</sup>	60 / 120 <sup>4</sup>
140	144	147 <sup>2</sup>	170	170	55	14	16	130
160	165	168	188	189	55	14	16	150
180	184	188	216	217	55	14	16	160
200	204	208 <sup>2</sup>	235	236	55	14	16	180
225	227	230	258	260	55	14	16	160
250	251	255	282	285	55	14	16	160
280	282	285	311	313	55	14	16	160
315	318	321	355	357	60 / 70	17	20	280
355	359	362	394	397	60 / 70	17	20	300

PIPE DIMENSIONS AND TOLERANCES

Our complete systems are designed for the pipe dimensions according to DIN EN 12201-2:2003 listed below. Multilayer pipes with different outer diameter than DIN EN 12201-2 are available in a variety of designs. These are not standardised and therefore outside diameters and materials used may vary to large extent.

⇒ Due to the additional layers OD's and material of the additive layer may vary (consultation with the producer is necessary, if there is a metal layer integrated); Please note the following pipe dimensions and tolerances.

SDR 11

DN	OD min		OD max		Wall thickness min		Wall thickness max		ID <sup>5</sup> [mm]
	DIN <sup>3</sup> [mm]	multilayer [mm]	DIN [mm]	multilayer [mm]	DIN [mm]	multilayer [mm]	DIN [mm]	multilayer [mm]	
63	63.0	64.0	63.4	65.7	5.8	6.5	6.5	7.6	51
75	75.0	77.0 <sup>2</sup>	75.5	79.0	6.8	7.8	7.6	9.1	61
90	90.0	92.0	90.6	94.0	8.2	9.3	9.2	10.7	73
110	110.0	112.0	110.7	114.0	10.0	11.1	11.1	12.7	89
125	125.0	127.0	125.8	129.0	11.4	12.5	12.7	14.2	101
140	140.0	143.0	140.9	145.0	12.7	14.0	14.1	15.9	113
160	160.0	163.0	161.0	166.0	14.6	15.8	16.2	18.0	129
180	180.0	183.0	181.1	186.0	16.4	17.6	18.2	20.0	145

SDR 17

DN	OD min		OD max		Wall thickness min		Wall thickness max		ID <sup>5</sup> [mm]
	DIN <sup>3</sup> [mm]	multilayer [mm]	DIN [mm]	multilayer [mm]	DIN [mm]	multilayer [mm]	DIN [mm]	multilayer [mm]	
90	90.0	92.0	90.6	94.0	5.3	5.4	6.0	6.5	79
110	110.0	112.0	110.7	114.0	6.5	7.5	7.8	8.6	97
125	125.0	127.0	125.8	129.0	7.4	8.5	8.3	9.8	110
140	140.0	143.0 <sup>2</sup>	140.9	145.0	8.3	9.4	9.3	11.1	123
160	160.0	163.0	161.0	166.0	9.5	10.7	10.6	12.4	140
180	180.0	183.0	181.1	186.0	10.7	11.9	11.9	13.7	158
200	200.0	203.0 <sup>2</sup>	201.2	206.0	11.9	13.1	13.2	15.0	176
225	225.0	225.0	226.4	230.0	13.4	14.6	14.9	16.6	197
250	250.0	250.0	251.5	255.0	14.8	16.0	16.4	18.3	220
280	280.0	280.0	281.7	286.0	16.6	17.8	18.4	20.1	246
315	315.0	315.0	316.9	321.0	18.7	19.9	20.7	22.4	277
355	355.0	355.0	357.2	361.0	21.1	22.3	23.4	25.1	312

<sup>2</sup> not available from our stock

<sup>3</sup> DIN ⇒ pipe dimensions according to DIN EN 12201-2

<sup>4</sup> bolt M16 for SDR 11

<sup>5</sup> ID = average pipe inside diameter



Components	Materials
Shells	AISI 316 L or similar
Bolts	A4 - 80
Bars	AISI 316 L
Liner insert	Carbon steel, Rilsan coated (W270, NSF61, WRAS)
Medium	all qualities of water
Temperature	-5°C up to 40°C <sup>6</sup>

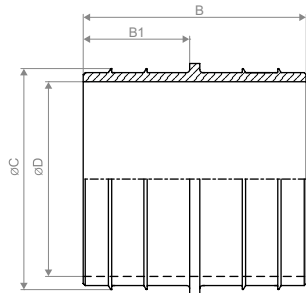

up to 110 mm: for PN 16 pipes <sup>6</sup>  
 from 125 mm: for PN 16 and PN 10 pipes <sup>6</sup>  
 > 180 mm: for PN 10 pipes <sup>6</sup>

**SDR 11**

OD [mm]	DIN <sup>3</sup>	Article multilayer	B [mm]	B1 [mm]	C [mm]	D [mm]	Weight [kg]
63.0	870070	870000	95	45.0	49.5	41.0	1.6
75.0	870075	870005 <sup>2</sup>	95	45.0	59.5	50.5	1.8
90.0	870080	870010	95	45.0	71.0	62.0	2.0
110.0	870085	870015	110	52.5	87.5	76.0	2.6
125.0	870089	870019	110	52.5	99.5	86.5	3.1
140.0	870094	870024 <sup>2</sup>	110	52.5	111.5	97.5	4.0
160.0	870099	870029	110	52.5	127.5	113.5	4.4
180.0	870104	870034	110	52.5	143.5	126.5	4.8

**SDR 17**

OD [mm]	DIN <sup>3</sup>	Article multilayer	B [mm]	B1 [mm]	C [mm]	D [mm]	Weight [kg]
90.0	870081	870011	95	45.0	77.0	66.8	2.1
110.0	870086	870016	110	52.5	94.5	82.3	2.7
125.0	870090	870020	110	52.5	108.0	95.0	3.0
140.0	870095	870025 <sup>2</sup>	110	52.5	121.0	107.0	3.8
160.0	870100	870030	110	52.5	138.5	124.5	4.3
180.0	870105	870035	110	52.5	156.0	139.0	5.1
200.0	870110	870040 <sup>2</sup>	110	52.5	173.5	154.5	5.5
225.0	870045	870045	110	52.5	195.0	173.0	9.1
250.0	870050	870050	110	52.5	217.0	193.0	10.2
280.0	870055	870055	110	52.5	243.0	217.0	11.9
315.0	870060	870060	130	62.5	273.0	243.0	19.6
355.0	870065	870065	130	62.5	308.0	274.0	23.2

**Remarks:**

- Test pressure at 20°C = 1.5 x PN
- Higher pressure rates on request
- For protecting pipes, please specify inside and outside diameters
- Pipe diameter range and tolerances ⇨ page 4
- Listed weight corresponds to the total product weight (liner insert and shells)

<sup>2</sup> not available from our stock

<sup>3</sup> DIN ⇨ pipe dimensions according to DIN EN 12201-2

<sup>6</sup> for permanent temperatures above 20°C, please note the pressure specifications for PE pipes according to DIN 8074

Components	Materials
Shells	AISI 316 L or similar
Bolts	A4 - 80
Bars	AISI 316 L
Liner insert	Carbon steel, Rilsan coated (W270, NSF61, WRAS)
Medium	all qualities of water
Temperature	-5°C up to 40°C <sup>6</sup>

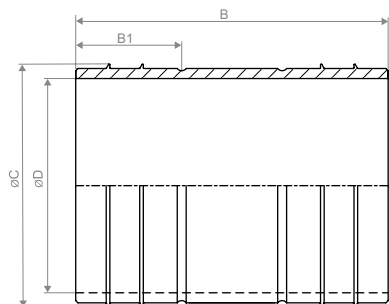

up to 110 mm: for PN 16 pipes <sup>6</sup>  
 from 125 mm: for PN 16 and PN 10 pipes <sup>6</sup>

SDR 11							
OD [mm]	DIN <sup>3</sup>	Article multilayer	B [mm]	B1 [mm]	C [mm]	D [mm]	Weight [kg]
63.0	871114	871100	195	47.5	49.5	40.0	1.9
75.0	871115	871101 <sup>2</sup>	195	47.5	59.5	49.5	2.2
90.0	871116	871102	195	47.5	71.0	61.0	2.6
110.0	871117	871103	210	55.0	87.5	75.0	3.0
125.0	871123	871127	210	55.0	99.5	85.5	4.0
140.0	871124	871128 <sup>2</sup>	210	55.0	111.5	97.5	5.2
160.0	871125	871129	210	55.0	127.5	113.5	5.8
180.0	871126	871130	210	55.0	143.5	126.5	6.7

SDR 17							
OD [mm]	DIN <sup>3</sup>	Article multilayer	B [mm]	B1 [mm]	C [mm]	D [mm]	Weight [kg]
90.0	871133	871131	195	47.5	77.0	66.8	2.7
110.0	871134	871132	210	55.0	94.5	82.3	3.1
125.0	871118	871104	210	55.0	108.0	94.0	4.4
140.0	871119	871105 <sup>2</sup>	210	55.0	121.0	107.0	5.4
160.0	871120	871106	210	55.0	138.5	124.5	6.1
180.0	871121	871107	210	55.0	156.0	139.0	7.1

**Remarks:**

- Before installing the repair coupler, expose 100 mm clearance between pipe ends
- Other repair-lengths and higher pressure rates on request
- Test pressure at 20°C = 1.5 x PN
- For protecting pipes, please specify inside and outside diameters
- Pipe diameter range and tolerances ⇒ page 4
- Listed weight corresponds to the total product weight (liner insert and shells)

<sup>2</sup> not available from our stock

<sup>3</sup> DIN ⇒ pipe dimensions according to DIN EN 12201-2

<sup>6</sup> for permanent temperatures above 20°C, please note the pressure specifications for PE pipes according to DIN 8074

<sup>7</sup> the O-ring prevents the liner from falling into the plastic pipe; O-ring has no sealing function

Components	Materials
Shells	AISI 316 L or similar
Bolts	A4 - 80
Bars	AISI 316 L
Liner insert	Carbon steel, Rilsan coated (W270, NSF61, WRAS)
Medium	all qualities of water
Temperature	-5°C up to 40°C <sup>6</sup>

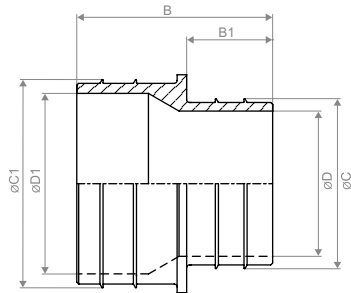

up to 110 mm: for PN 16 pipes <sup>6</sup>  
 from 125 mm: for PN 10 pipes <sup>6</sup>

SDR 11

OD [mm]	Article DIN <sup>3</sup>	Article multilayer	B [mm]	B1 [mm]	C [mm]	C1 [mm]	D [mm]	D1 [mm]	Weight [kg]
90.0x63.0	870235	870155	95.0	45.0	49.5	71.0	41.0	62.0	2.0
110.0x90.0	870240	870160	102.5	52.5/45.0	71.0	87.5	62.0	76.0	2.5
125.0x110.0	870245	870165	110.0	52.5	87.5	99.5	76.0	86.5	3.3
160.0x110.0	870260	870176	110.0	52.5	87.5	127.5	76.0	113.5	5.0
160.0x125.0	870270	870180	110.0	52.5	99.5	127.5	86.5	113.5	4.8
180.0x160.0	870280	870189	110.0	52.5	127.5	143.5	113.5	126.5	5.4

SDR 17

OD [mm]	Article DIN <sup>3</sup>	Article multilayer	B [mm]	B1 [mm]	C [mm]	C1 [mm]	D [mm]	D1 [mm]	Weight [kg]
90.0x63.0	870236	870156	95.0	45.0	49.5	77.0	41.0	66.8	2.2
110.0x90.0	870241	870161	102.5	45.0	77.0	94.5	66.8	82.3	2.6
125.0x110.0 <sup>8</sup>	870250	870170	110.0	52.5	87.5	108.0	76.0	95.0	3.2
160.0x110.0 <sup>8</sup>	870185	870178	110.0	52.5	87.5	138.5	76.0	124.5	5.4
160.0x125.0	870195	870182	110.0	52.5	108.0	138.5	95.0	124.5	5.8
180.0x125.0	870205	870190	110.0	52.5	108.0	156.0	95.0	139.0	6.2

Remarks:

- Test pressure at 20°C = 1.5 x PN
- Higher pressure ratings and additional dimensions are available on request
- For protecting pipes, please specify inside and outside diameters
- Pipe diameter range and tolerances ⇨ page 4
- Listed weight corresponds to the total product weight (liner insert and shells)

<sup>3</sup> DIN ⇨ pipe dimensions according to DIN EN 12201-2

<sup>6</sup> for permanent temperatures above 20°C, please note the pressure specifications for PE pipes according to DIN 8074

<sup>8</sup> OD 110 mm in SDR 11

Components	Materials
Shells	AISI 316 L or similar
Bolts	A4 - 80
Bars	AISI 316 L
Liner insert	Carbon steel, Rilsan coated (W270, NSF61, WRAS)
Medium	all qualities of water
Temperature	-5°C up to 40°C <sup>6</sup>

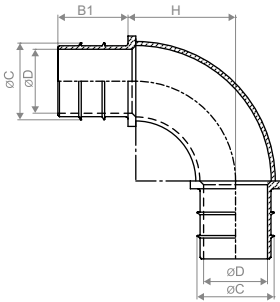

up to 110 mm: for PN 16 pipes <sup>6</sup>  
 from 125 mm: for PN 16 and PN 10 pipes <sup>6</sup>  
 > 180 mm: for PN 10 pipes <sup>6</sup>

SDR 11

OD [mm]	DIN <sup>3</sup>	Article multilayer	B1 [mm]	C [mm]	D [mm]	H [mm]	Weight [kg]
63.0	870520	870450	45.0	49.5	41.0	69.0	2.0
75.0	870525	870455 <sup>2</sup>	45.0	59.5	50.5	77.0	2.3
90.0	870530	870460	45.0	71.0	62.0	97.0	3.2
110.0	870535	870465	52.5	87.5	76.0	122.0	3.7
125.0	870539	870469	52.5	99.5	86.5	138.0	6.1
140.0	870544	870474 <sup>2</sup>	52.5	111.5	97.5	147.0	6.9
160.0	870549	870479	52.5	127.5	113.5	180.0	9.3
180.0	870554	870484	52.5	143.5	126.5	200.0	10.6

SDR 17

OD [mm]	DIN <sup>3</sup>	Article multilayer	B1 [mm]	C [mm]	D [mm]	H [mm]	Weight [kg]
90.0	870531	870461	45.0	77.0	66.8	100.0	3.3
110.0	870536	870466	52.5	94.5	82.3	122.0	3.8
125.0	870540	870470	52.5	108.0	95.0	147.0	6.0
140.0	870545	870475 <sup>2</sup>	52.5	121.0	107.0	157.0	7.1
160.0	870550	870480	52.5	138.5	124.5	195.0	8.3
180.0	870555	870485	52.5	156.0	139.0	226.0	10.8
225.0	870495 <sup>2</sup>	870495 <sup>2</sup>	52.5	195.0	173.0	280.0	19.6
250.0	870500 <sup>2</sup>	870500 <sup>2</sup>	52.5	217.0	193.0	325.0	26.0
280.0	870505 <sup>2</sup>	870505 <sup>2</sup>	52.5	243.0	217.0	398.0	37.0
315.0	870510 <sup>2</sup>	870510 <sup>2</sup>	52.5	273.0	243.0	401.0	44.5
355.0	870515 <sup>2</sup>	870515 <sup>2</sup>	52.5	308.0	274.0	477.0	63.2

Remarks:

- Test pressure at 20°C = 1.5 x PN
- Higher pressure ratings and additional dimensions are available on request
- For protecting pipes, please specify inside and outside diameters
- Pipe diameter range and tolerances ⇨ page 4
- Listed weight corresponds to the total product weight (linser insert and shells)

<sup>2</sup> not available from our stock

<sup>3</sup> DIN ⇨ pipe dimensions according to DIN EN 12201-2

<sup>6</sup> for permanent temperatures above 20°C, please note the pressure specifications for PE pipes according to DIN 8074



Components	Materials
Shells	AISI 316 L or similar
Bolts	A4 - 80
Bars	AISI 316 L
Liner insert	Carbon steel, Rilsan coated (W270, NSF61, WRAS)
Medium	all qualities of water
Temperature	-5°C up to 40°C <sup>6</sup>

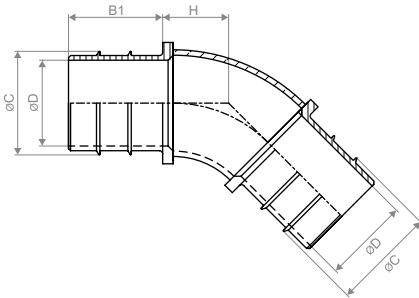

up to 110 mm: for PN 16 pipes <sup>6</sup>  
 from 125 mm: for PN 16 and PN 10 pipes <sup>6</sup>  
 > 180 mm: for PN 10 pipes <sup>6</sup>

SDR 11							
OD [mm]	DIN <sup>3</sup>	Article multilayer	B1 [mm]	C [mm]	D [mm]	H [mm]	Weight [kg]
63.0	870642	870600	45.0	49.5	41.0	32.0	1.8
75.0	870645	870603 <sup>2</sup>	45.0	59.5	50.5	35.0	2.0
90.0	870648	870606	45.0	71.0	62.0	43.0	2.3
110.0	870651	870609	52.5	87.5	76.0	53.0	3.1
125.0	870653	870611	52.5	99.5	86.5	60.0	4.9
140.0	870656	870614 <sup>2</sup>	52.5	111.5	97.5	64.0	5.2
160.0	870659	870617	52.5	127.5	113.5	77.5	7.4
180.0	870662	870620	52.5	143.5	126.5	89.0	8.1

SDR 17							
OD [mm]	DIN <sup>3</sup>	Article multilayer	B1 [mm]	C [mm]	D [mm]	H [mm]	Weight [kg]
90.0	870649	870607	45.0	77.0	66.8	44.4	2.4
110.0	870652	870610	52.5	94.5	82.3	53.5	3.2
125.0	870654	870612	52.5	108.0	95.0	64.0	4.9
140.0	870657	870615 <sup>2</sup>	52.5	121.0	107.0	68.0	6.5
160.0	870660	870618	52.5	138.5	124.5	84.0	7.7
180.0	870663	870621	52.5	156.0	139.0	94.0	8.2
225.0	870627 <sup>2</sup>	870627 <sup>2</sup>	52.5	195.0	173.0	117.0	14.9
250.0	870630 <sup>2</sup>	870630 <sup>2</sup>	52.5	217.0	193.0	131.0	18.5
280.0	870633 <sup>2</sup>	870633 <sup>2</sup>	52.5	243.0	217.0	162.0	25.0
315.0	870636 <sup>2</sup>	870636 <sup>2</sup>	52.5	273.0	243.0	163.0	32.0
355.0	870639 <sup>2</sup>	870639 <sup>2</sup>	52.5	308.0	274.0	194.0	43.2

**Remarks:**

- Test pressure at 20°C = 1.5 x PN
- Higher pressure ratings and additional dimensions are available on request
- For protecting pipes, please specify inside and outside diameters
- Pipe diameter range and tolerances ⇨ page 4
- Listed weight corresponds to the total product weight (linser insert and shells)

<sup>2</sup> not available from our stock

<sup>3</sup> DIN ⇨ pipe dimensions according to DIN EN 12201-2

<sup>6</sup> for permanent temperatures above 20°C, please note the pressure specifications for PE pipes according to DIN 8074

Components	Materials
Shells	AISI 316 L or similar
Bolts	A4 - 80
Bars	AISI 316 L
Liner insert	Carbon steel, Rilsan coated (W270, NSF61, WRAS)
Medium	all qualities of water
Temperature	-5°C up to 40°C <sup>6</sup>

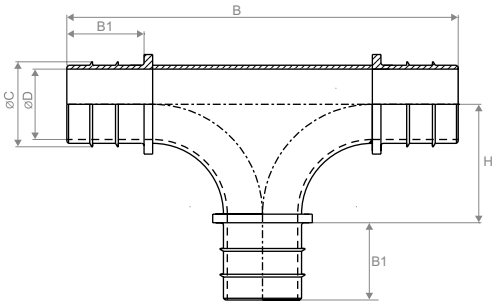

up to 110 mm: for PN 16 pipes <sup>6</sup>  
 from 125 mm: for PN 16 and PN 10 pipes <sup>6</sup>  
 > 180 mm: for PN 10 pipes <sup>6</sup>

SDR 11								
OD [mm]	DIN <sup>3</sup>	Article multilayer	B [mm]	B1 [mm]	C [mm]	D [mm]	H [mm]	Weight [kg]
63.0	870370	870300	214.0	45.0	49.5	41.0	62.0	3.0
75.0	870375	870305 <sup>2</sup>	228.0	45.0	59.5	50.5	69.0	4.0
90.0	870380	870310	252.0	45.0	71.0	62.0	81.0	5.3
110.0	870385	870315	287.0	52.5	87.5	76.0	91.0	7.4
125.0	870389	870319	315.0	52.5	99.5	86.5	105.0	7.5
140.0	870394	870324 <sup>2</sup>	315.0	52.5	111.5	97.5	105.0	8.2
160.0	870399	870329	355.0	52.5	127.5	113.5	125.0	11.6
180.0	870404	870334	363.0	52.5	143.5	126.5	129.0	12.2

SDR 17								
OD [mm]	DIN <sup>3</sup>	Article multilayer	B [mm]	B1 [mm]	C [mm]	D [mm]	H [mm]	Weight [kg]
90.0	870381	870311	252.0	45.0	77.0	66.8	81.0	5.4
110.0	870386	870316	287.0	52.5	94.5	82.3	91.0	7.5
125.0	870390	870320	325.0	52.5	108.0	95.0	110.0	8.9
140.0	870395	870325 <sup>2</sup>	325.0	52.5	121.0	107.0	110.0	12.5
160.0	870400	870330	363.0	52.5	138.5	124.5	129.0	16.1
180.0	870405	870335	401.0	52.5	156.0	139.0	148.0	19.0
225.0	870345 <sup>2</sup>	870345 <sup>2</sup>	401.0	52.5	195.0	173.0	148.0	20.1
250.0	870350 <sup>2</sup>	870350 <sup>2</sup>	471.0	52.5	217.0	193.0	183.0	24.5
280.0	870355 <sup>2</sup>	870355 <sup>2</sup>	471.0	52.5	243.0	217.0	183.0	28.6
315.0	870360 <sup>2</sup>	870360 <sup>2</sup>	547.0	52.5	273.0	243.0	221.0	44.4
355.0	870365 <sup>2</sup>	870365 <sup>2</sup>	623.0	52.5	308.0	274.0	259.0	53.8

**Remarks:**

- Test pressure at 20°C = 1.5 x PN
- Higher pressure ratings and additional dimensions are available on request
- For protecting pipes, please specify inside and outside diameters
- Pipe diameter range and tolerances ⇒ page 4
- Listed weight corresponds to the total product weight (liner insert and shells)

<sup>2</sup> not available from our stock

<sup>3</sup> DIN ⇒ pipe dimensions according to DIN EN 12201-2

<sup>6</sup> for permanent temperatures above 20°C, please note the pressure specifications for PE pipes according to DIN 8074

Components	Materials
Shells	AISI 316 L or similar
Bolts	A4 - 80
Bars	AISI 316 L
Liner insert	Carbon steel, Rilsan coated (W270, NSF61, WRAS)
Medium	all qualities of water
Temperature	-5°C up to 40°C <sup>6</sup>

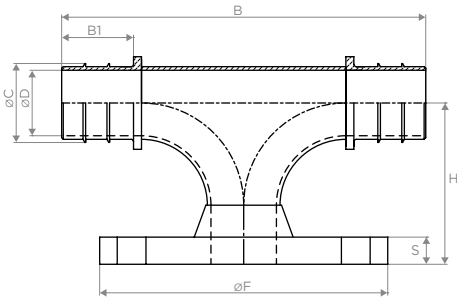

up to 110 mm: for PN 16 pipes <sup>6</sup>  
 from 125 mm: for PN 10 pipes <sup>6</sup>

SDR 11

OD [mm]	Article DIN <sup>3</sup>	Article multilayer	B [mm]	B1 [mm]	C [mm]	D [mm]	H [mm]	F [mm]	S [mm]	Flange PN 16	Bolts Quan./Dim.	Weight [kg]
90.0	870757	870703	252.0	45.0	71.0	62.0	176.0	200	20	DN 80	8x, M16	8.9
90.0	870760	870706	252.0	45.0	71.0	62.0	178.0	220	20	DN 100	8x, M16	9.1
110.0	870763	870709	287.0	52.5	87.5	76.0	136.0	200	20	DN 80	8x, M16	9.5
110.0	870766	870712	287.0	52.5	87.5	76.0	188.0	220	20	DN 100	8x, M16	9.7

SDR 17

OD [mm]	Article DIN <sup>3</sup>	Article multilayer	B [mm]	B1 [mm]	C [mm]	D [mm]	H [mm]	F [mm]	S [mm]	Flange PN 10	Bolts Quan./Dim.	Weight [kg]
90.0	870758	870704	252.0	45.0	77.0	66.8	176.0	200	20	DN 80	8x, M16	9.0
90.0	870761	870707	252.0	45.0	77.0	66.8	178.0	220	20	DN 100	8x, M16	9.2
110.0	870764	870710	287.0	52.5	94.5	82.3	136.0	200	20	DN 80	8x, M16	9.6
110.0	870767	870713	287.0	52.5	94.5	82.3	188.0	220	20	DN 100	8x, M16	9.8
125.0	870769	870715	287.0	52.5	108.0	95.0	136.0	200	20	DN 80	8x, M16	12.0
125.0	870772	870718	325.0	52.5	108.0	95.0	157.0	220	20	DN 100	8x, M16	12.2
160.0	870775	870721	287.0	52.5	138.5	124.5	161.0	200	20	DN 80	8x, M16	16.2
160.0	870778	870724	325.0	52.5	138.5	124.5	169.0	220	20	DN 100	8x, M16	16.9
160.0	870781	870727	363.0	52.5	138.5	124.5	229.0	285	22	DN 150	8x, M20	20.4
180.0	870784	870730	325.0	52.5	156.0	139.0	174.0	200	20	DN 80	8x, M16	19.6
180.0	870787	870733	325.0	52.5	156.0	139.0	182.0	220	20	DN 100	8x, M16	20.0
180.0	870790	870736	401.0	52.5	156.0	139.0	198.0	285	22	DN 150	8x, M20	23.4

Remarks:

- Flange according to DIN 2633 / EN 1092-1
- Test pressure at 20°C = 1.5 x PN
- Higher pressure ratings and additional dimensions are available on request
- For protecting pipes, please specify inside and outside diameters
- Pipe diameter range and tolerances ⇒ page 4
- Listed weight corresponds to the total product weight (liner insert and shells)
- Flange bolt set is not supplied

<sup>3</sup> DIN ⇒ pipe dimensions according to DIN EN 12201-2

<sup>6</sup> for permanent temperatures above 20°C, please note the pressure specifications for PE pipes according to DIN 8074

Components	Materials
Shells	AISI 316 L or similar
Bolts	A4 - 80
Bars	AISI 316 L
Liner insert	Carbon steel, Rilsan coated (W270, NSF61, WRAS)
Medium	all qualities of water
Temperature	-5°C up to 40°C <sup>6</sup>

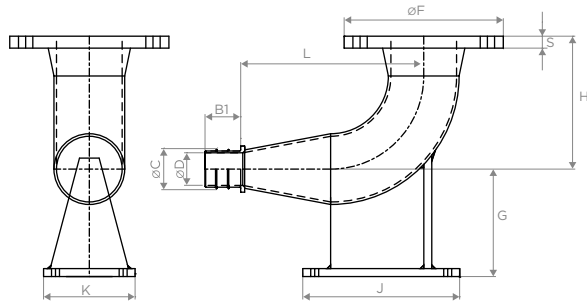

up to 110 mm: for PN 16 pipes <sup>6</sup>  
 from 125 mm: for PN 10 pipes <sup>6</sup>

SDR 11

OD [mm]	Article DIN <sup>3</sup>	Article multilayer	B1 [mm]	C [mm]	D [mm]	H [mm]	F [mm]	G [mm]	J [mm]	K [mm]	L [mm]	S [mm]	Flange PN 16	Bolts Quan./Dim.	Weight [kg]
63.0	870850	870800	45.0	49.5	41.0	167.0	200	135.0	152.0	90	275.0	20	DN 80	8x, M16	9.4
90.0	870855	870805	45.0	71.0	62.0	167.0	200	135.0	152.0	115	235.0	20	DN 80	8x, M16	10.0
110.0	870860	870810	52.5	87.5	76.0	167.0	200	135.0	152.0	130	230.5	20	DN 80	8x, M16	10.7

SDR 17

OD [mm]	Article DIN <sup>3</sup>	Article multilayer	B1 [mm]	C [mm]	D [mm]	H [mm]	F [mm]	G [mm]	J [mm]	K [mm]	L [mm]	S [mm]	Flange PN 10	Bolts Quan./Dim.	Weight [kg]
90.0	870856	870806	45.0	77.0	66.8	167.0	200	135.0	152.0	115	190.0	20	DN 80	8x, M16	10.1
110.0	870861	870811	52.5	94.5	82.3	167.0	200	135.0	152.0	130	178.0	20	DN 80	8x, M16	10.8
125.0	870865	870815	52.5	108.0	95.0	167.0	200	135.0	152.0	150	242.5	20	DN 80	8x, M16	11.1
160.0	870870	870820	52.5	138.5	124.5	167.0	200	135.0	152.0	180	309.5	20	DN 80	8x, M16	16.2
180.0	870875	870825	52.5	156.0	139.0	167.0	200	135.0	152.0	200	346.5	20	DN 80	8x, M16	19.2

Remarks:

- Flange according to DIN 2633 / EN 1092-1
- Test pressure at 20°C = 1.5 x PN
- Higher pressure ratings and additional dimensions are available on request
- For protecting pipes, please specify inside and outside diameters
- Pipe diameter range and tolerances ⇒ page 4
- Listed weight corresponds to the total product weight (liner insert and shells)
- Flange bolt set is not supplied

<sup>3</sup> DIN ⇒ pipe dimensions according to DIN EN 12201-2

<sup>6</sup> for permanent temperatures above 20°C, please note the pressure specifications for PE pipes according to DIN 8074

Components	Materials
Shells	AISI 316 L or similar
Bolts	A4 - 80
Bars	AISI 316 L
Liner insert	Carbon steel, Rilsan coated (W270, NSF61, WRAS)
Medium	all qualities of water
Temperature	-5°C up to 40°C <sup>6</sup>

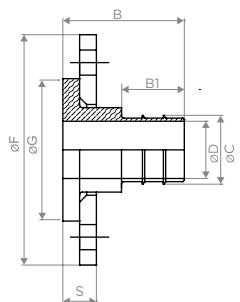

up to 110 mm: for PN 16 pipes <sup>6</sup>  
 from 125 mm: for PN 16 and PN 10 pipes <sup>6</sup>  
 > 180 mm: for PN 10 pipes <sup>6</sup>

SDR 11

OD [mm]	Article DIN <sup>3</sup>	Article multilayer	B [mm]	B1 [mm]	C [mm]	D [mm]	F [mm]	G° [mm]	S [mm]	Flange PN 16	Bolts Quan./Dim.	Weight [kg]
63.0	870936	870900	83.0	45.0	49.5	41.0	165	107.0	28	DN 50	4x, M16	2.4
63.0	870939	870903	85.0	45.0	49.5	41.0	202	142.0	30	DN 80	8x, M16	4.1
75.0	870942	870904 <sup>2</sup>	85.0	45.0	59.5	50.5	187	127.0	28	DN 65	4x, M16	3.4
90.0	870945	870906	85.0	45.0	71.0	62.0	202	142.0	30	DN 80	8x, M16	3.8
110.0	870948	870909	92.5	52.5	87.5	76.0	220	162.0	30	DN 100	8x, M16	4.0
125.0	870963	870910	92.5	52.5	99.5	86.5	220	162.0	30	DN 100	8x, M16	4.6
140.0	870966	870911 <sup>2</sup>	92.5	52.5	111.5	97.5	250	192.0	34	DN 125	8x, M16	6.6
160.0	870969	870914	104.5	52.5	127.5	113.5	286	218.0	36	DN 150	8x, M20	11.1
180.0	870972	870917	104.5	52.5	143.5	126.5	286	218.0	36	DN 150	8x, M20	10.2

SDR 17

OD [mm]	Article DIN <sup>3</sup>	Article multilayer	B [mm]	B1 [mm]	C [mm]	D [mm]	F [mm]	G° [mm]	S [mm]	Flange PN 10	Bolts Quan./Dim.	Weight [kg]
90.0	970946	970907	85.0	45.0	77.0	66.8	200	138.0	30	DN 80	8x, M16	3.9
110.0	870949	870908	92.5	52.5	94.5	82.3	218	158.0	30	DN 100	8x, M16	5.0
125.0	870951	870912	92.5	52.5	108.0	95.0	220	162.0	30	DN 100	8x, M16	4.2
140.0	870954	870913 <sup>2</sup>	92.5	52.5	121.0	107.0	250	192.0	34	DN 125	8x, M16	6.1
160.0	870957	870915	104.5	52.5	138.5	124.5	286	218.0	36	DN 150	8x, M20	10.2
180.0	870960	870918	104.5	52.5	156.0	139.0	286	218.0	36	DN 150	8x, M20	9.0
200.0	870975	870920 <sup>2</sup>	127.0	52.5	173.5	154.5	340	273.0	39	DN 200	8x, M20	19.2
225.0	870922	870922	127.0	52.5	195.0	173.0	340	273.0	39	DN 200	8x, M20	17.7
250.0	870924	870924	133.0	52.5	217.0	193.0	409	328.0	45	DN 250	12x, M20	31.7
280.0	870926	870926	133.0	52.5	243.0	217.0	409	328.0	45	DN 250	12x, M20	27.0
315.0	870928	870928	150.0	62.5	273.0	243.0	463	378.0	52	DN 300	12x, M20	40.7
355.0	870930	870930	158.0	62.5	308.0	274.0	515	438.0	60	DN 350	16x, M20	54.5

Remarks:

- Flange according to DIN 2633 / EN 1092-1, hole pattern according to EN 1092-1
- Test pressure at 20°C = 1.5 x PN
- Higher pressure ratings and additional dimensions are available on request
- For protecting pipes, please specify inside and outside diameters
- Pipe diameter range and tolerances ⇒ page 4
- Listed weight corresponds to the total product weight (liner insert and shells)
- Flange bolt set is not supplied

<sup>2</sup> not available from our stock

<sup>3</sup> DIN ⇒ pipe dimensions according to DIN EN 12201-2

<sup>6</sup> for permanent temperatures above 20°C, please note the pressure specifications for PE pipes according to DIN 8074

<sup>9</sup> outside diameter for gasket



## THE REPAIR CONCEPT

(Repair-Coupler)

Damaged PE pipes can easily be repaired with the STRAUB-PLAST-PRO repair-coupler. Repairs up to a length of 100 mm are possible.

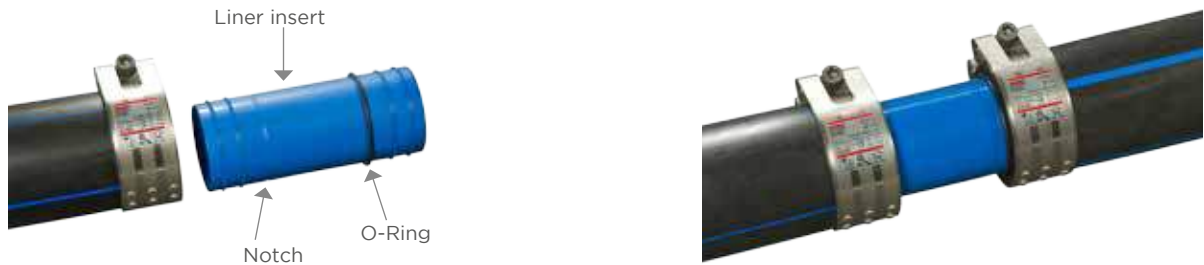

Expose 100 mm of pipe. Slightly bend the pipe ends sideward and insert the repair coupler to the O-Ring into one of the two pipe ends. Align the shells to the pipe ends.

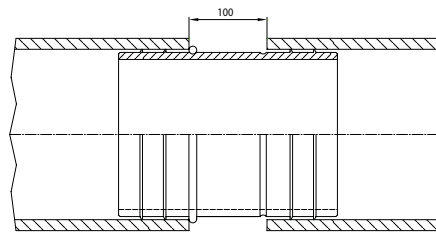

The pipe ends may be centred to each other again and the repair couplers aligned using the notches on the inner coupler. The clamps are to be tightened according to the torque indicated on the label.

The O-Ring prevents the repair coupler from completely sliding into the pipe.



Due to the variety of possible applications, STRAUB-PLAST-PRO is the genuine alternative to welding of PE pipes.



## EXAMPLE STRAUB-PLAST-PRO R

(Reducer)

1



Slide the Shells over both pipes.

2



Push the reducer into the first tube until it stops.

3



Push the tubes together as far as they will go.

4



Align the shells to the pipe ends.

5



Tighten the locking bolts alternately with a torque wrench to the final torque rate indicated on the label of the shell. Repeat alternately the tightening sequence until a quarter turn (90°) or less is needed to reach the required torque.

- Complete kit
- Quickly and easily installed
- Installation without the need of external power supply
- May be installed in adverse weather conditions
- For pipe connections in contaminated soils
- Highly resistant against corrosion
- No pipe end preparation is required
- No dead end
- Stronger than a PE 100 pipe

## LIABILITY DISCLAIMER

The information and data in this leaflet are intended to assist the user in the proper selection of STRAUB products. This information may contain inaccuracies or typographical errors. Furthermore, all the information contained in this leaflet list is subject to change by STRAUB Werke AG without prior notice as a result of product re-designs, product improvements or other reasons.

STRAUB Werke AG accepts no liability for damage arising as a result of the use of data, diagrams or application examples in this leaflet.



**MV Fluids Handling**  
Marven Hosue, 1 Field Road, Reading, RG1 6AP  
Tel +44 (0)118 9503707 – Fax +44 (0)118 9504066  
info@straub.co.uk

[www.straub.co.uk](http://www.straub.co.uk)